

Product Data Submittal

2-30-1500 and 2-30-1501

Deluxe Chemical Feed System

Dimensions

A. Height	IN	47
	MM	1194
B. Width	IN	23
	MM	584
C. Depth	IN	23
	MM	584

Specifications

System Capacity	Gal	50
	Liters	189.2
System Weight (empty)	LB	35
	KG	15.87
System Weight (full)	LB	452
	KG	205.02
Pump Rated Pressure	PSI	150
	BAR	10
Pump Output	GPH	0.6
	LPH	2.27
Pump Voltage	120/230VAC	
Pump Discharge Piping	3/8" Polypropylene Tubing	

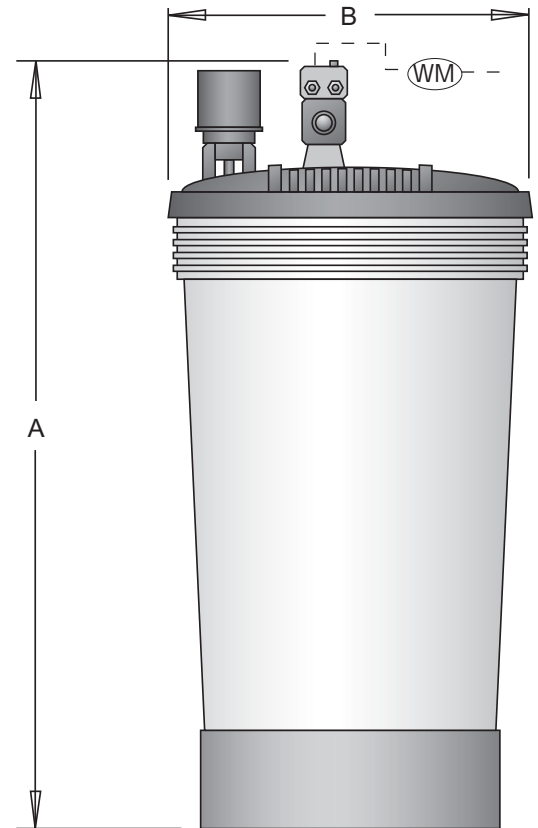

Front View

Standard Components:

- (1) 50 gallon polyethylene tank w/lid (944-3C)
- (1) Proportional chemical metering pump (EWB11Y1(or2)-PE)
- (1) Tank agitator w/ ss agitator (60283XFB)
- (1) Set of suction/discharge tubing including quill
- (1) Water Meter with hall effect sensor (10 pulses/gallon)

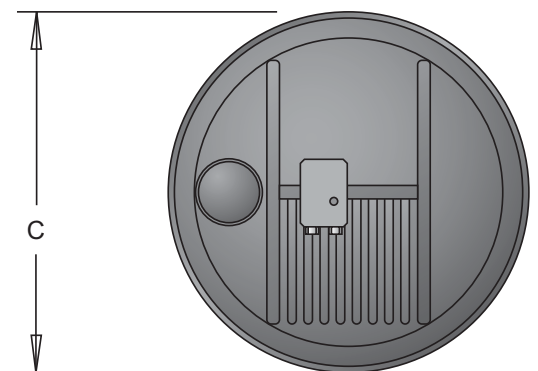

Top View

Metering Pump

Dimensions (in inches)

A. 7.36	B. 1.46	C. 0.83	D. 2.64	E. 1.57	F. 0.20
G. 3.94	H. 0.31	I. 3.54	J. 5.91	K. 7.24	

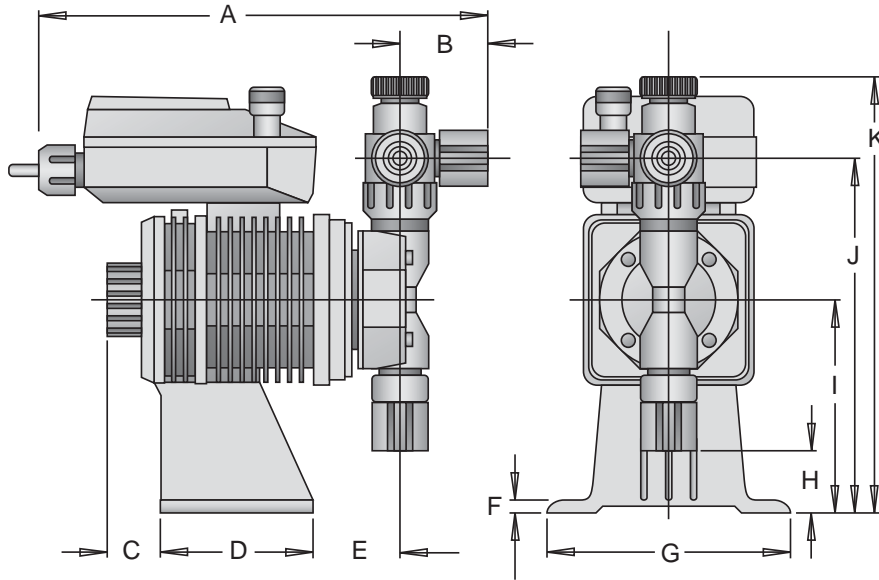

The EH Series metering pumps have been UL tested to meet UL and CSA standards.



2 Year Limited Warranty

The manufacturer will repair or replace any properly applied pump if it fails up to 2 years after delivery. This warranty covers the metering pump electronics (control unit and drive unit) and the entire liquid end, including diaphragm.

Specifications

Fulton Model Number	2-30-1500	2-30-1501
Motor Frequency	50/60 Hz, Single Phase	50/60 Hz, Single Phase
Motor Voltage	115 VAC \pm 10%	230 VAC \pm 10%
Amp Draw	0.8 Amp max.	0.4 Amp max.
Power Requirement	16 Watt avg.	16 Watt avg.
Operating Conditions		
Ambient Temperature	32°F-122°F/0°C-50°C	32°F-122°F/0°C-50°C

Agitator

Specifications

Fulton Model Number	2-30-1500	2-30-1501
Motor Speed	1600 RPM	1600 RPM
Motor Frequency	50/60 Hz	50 Hz
Motor Voltage	115 VAC	220-240 VAC
Amp Draw	2.0 Amp	1.0 Amp
Power Requirement	175 Watt	175 Watt
Impeller	303 S.S.+	303 S.S.+
Shaft Length	34" S.S.+	34" S.S.+

+ Epoxy chemical resistant coating.

